

6 Underground Requirements

6.1 Underground Service

The Customer is responsible for the trenching, backfilling, compaction, conduit, transformer pads or vaults, and any other requirements to complete the construction for underground service. For transformer installations, the Customer must provide space for the transformer. For all trenching and transformer installations, the customer must meet any requirements of governmental authorities (including excavation permits) and PGE.

Where exposed to motorized vehicles, the customer must install and maintain PGE approved barriers to protect padmounted transformers and other equipment. (See [Figure 6-4.](#))

In most cases, PGE will install, maintain, and own the underground service lateral from PGE's distribution line or transformer to the point of delivery. No bends will be allowed in the conduit riser between the meter base and the underground sweep. If local codes do not allow conduit in the foundation and/or footings, a surface mounted meter must be installed.

PGE will install conductors in Customer-provided conduit. A long sweep elbow is required at the bottom of the service riser conduit in all cases.

Field heat bends are not acceptable. All bends must be factory made.

Refer to the [Table 6-1, \(Conduit Requirements for Utility Conductors\)](#), for the minimum conduit acceptable for PGE service lateral conductors. Contact PGE for conduit requirements if primary voltage conductors are to be installed.

Where a Customer's conduit extends vertically through a paved or concrete surface adjacent to the service entrance, place a sleeve around the conduit to prevent direct contact of the conduit with the pavement. This helps avoid damage to conductors and service equipment caused by soil settling. (See [Figure 7-4.](#), note 2)

Where a Customer's conduit extends to a PGE pole, the Customer must provide the 90-degree large radius sweep (see [Table 6-1](#)). Consult PGE for the exact location on the pole. See [Section 6.3, Conduit](#), for approved conduit material.

Cap all conduits at BOTH ends during installation to keep them free of dirt and debris. All conduits must have a non-conductive pull line, 500 lb. rated, with 6 feet extending from each end.

All conduits shall be permanently attached along all conduit sections, including couplings, adapters, sweeps, and termi-duct fittings, using either PVC glue or other permanent mechanical joints.

The Customer is responsible for repairing, or the costs associated with repairing, any conduit problems prior to the installation of PGE conductors. PGE will own and maintain the conduit system once PGE conductors have been installed.

6.2 Trenches Provided by the Customer

Customers shall be in compliance with OSHA rules and OUCC standards. PGE requires the spoils be kept at least two feet away from the open trench when the trench is not shored. The Customer must shore the trench when any combination of trench depth plus spoil exceeds five feet. Also see [Section 7.2, Underground Service](#).

The location of the service entrance on the Customer's premises is an important consideration to both the Customer and PGE. Customer responsibilities include:

- Consulting PGE to determine the route and the point of attachment for underground service laterals, meter locations, service outlet locations, current transformers, and terminal cabinet enclosures. Routing conduit under buildings or other permanent obstructions should be avoided; exceptions may be allowed with approval from PGE if alternative routes are not available. Special construction methods or materials may be required.
- Locating the service entrance to make the meter and service easily accessible from PGE distribution lines and convenient for the installation, operation, and maintenance of PGE meters and equipment.
- The Customer is responsible to recognize potential surface and subgrade water flows that may allow the entry of water into the Customer's electrical equipment. PGE will coordinate with the Customer to assist in preventing this water entry.
- A permit from the local jurisdiction is required before any work in the right-of-way may be performed. Only PGE approved excavation contractors and contractors who have made other special agreements with PGE will be allowed to work under PGE's permit. The contractor must notify the local jurisdiction 48 hours before the work is to begin. A copy of the permit must be on site.

6.2.1 Call Before You Dig

State laws require the Customer/Excavator to call for underground utility cable locations at least two full working days (48 hours) prior to excavation. The excavation must not be started until locations have been marked or the utilities have informed the excavator that they have no facilities in the area. **Call 811 or 1-800-332-2344 before you dig. For Portland Metro call 503-246-6699. Website: www.digsafelyoregon.com**

6.2.2 Service Trench

When installing only service cable in the trench, follow "Service Trench" dimensions in [Figure 6-1](#). When installing service cable with other telecommunication utilities (telephone, cable T.V.) follow "Joint Use Trench Without Gas" [Figure 6-2](#) or "Joint Use Trench With Gas" [Figure 6-3](#).

6.2.3 Select Backfill

Trench depth shall include requirements for select backfill as necessary to protect cables installed in rocky soil conditions. Figures 6-1, 6-2, and 6-3 provide select back fill depth requirements.

Select backfill are materials that pass through a 3/4" sieve and contain no sharp or foreign objects.

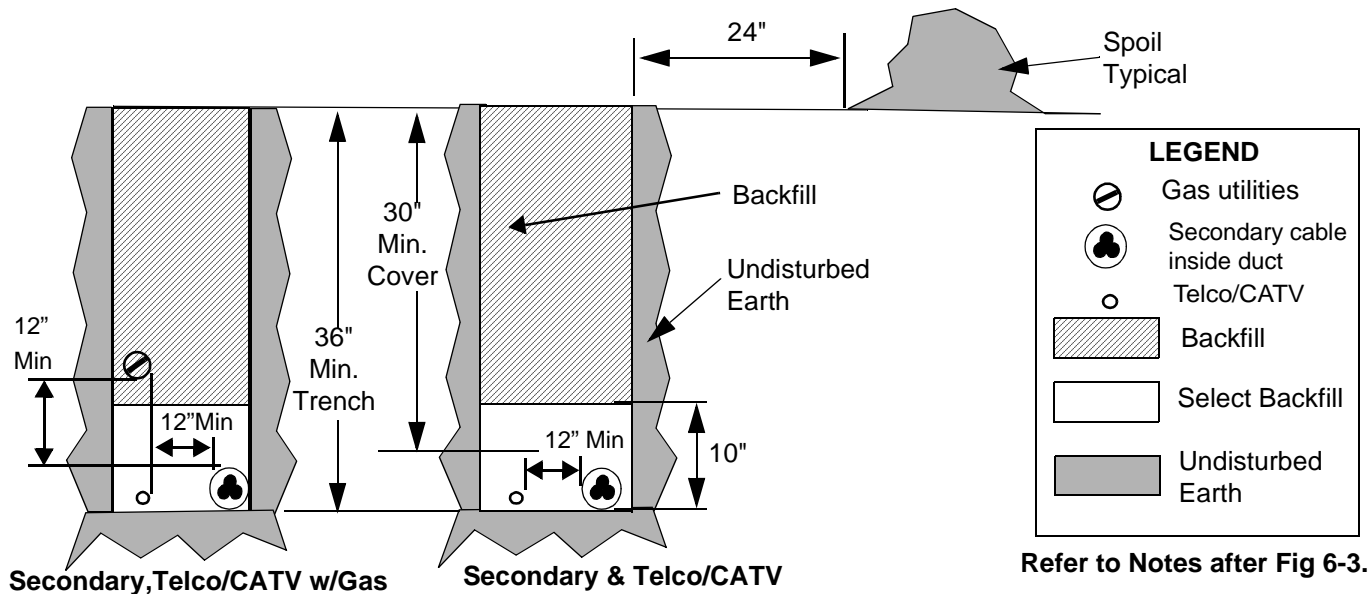

Figure 6-1 Service Trench

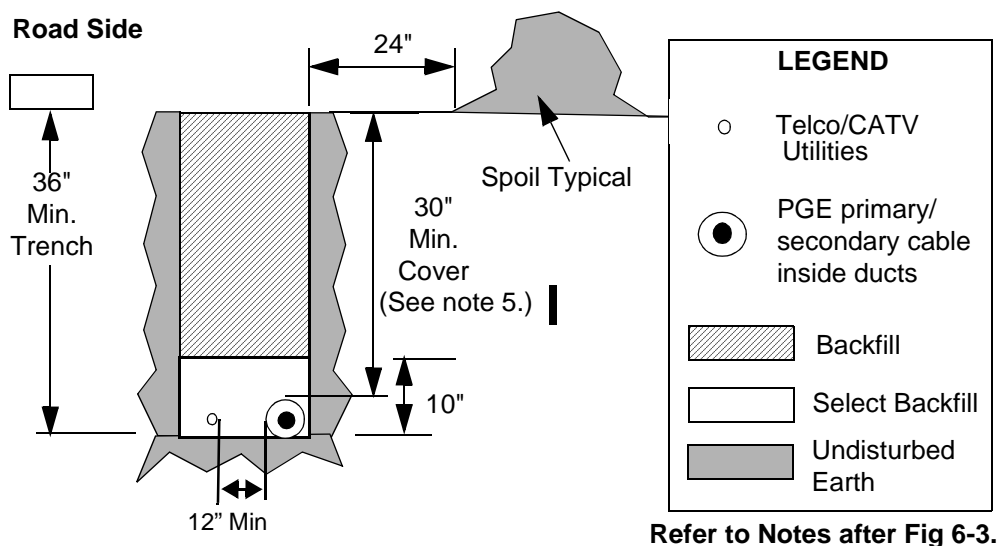

Figure 6-2 Joint Use Trench Without Gas

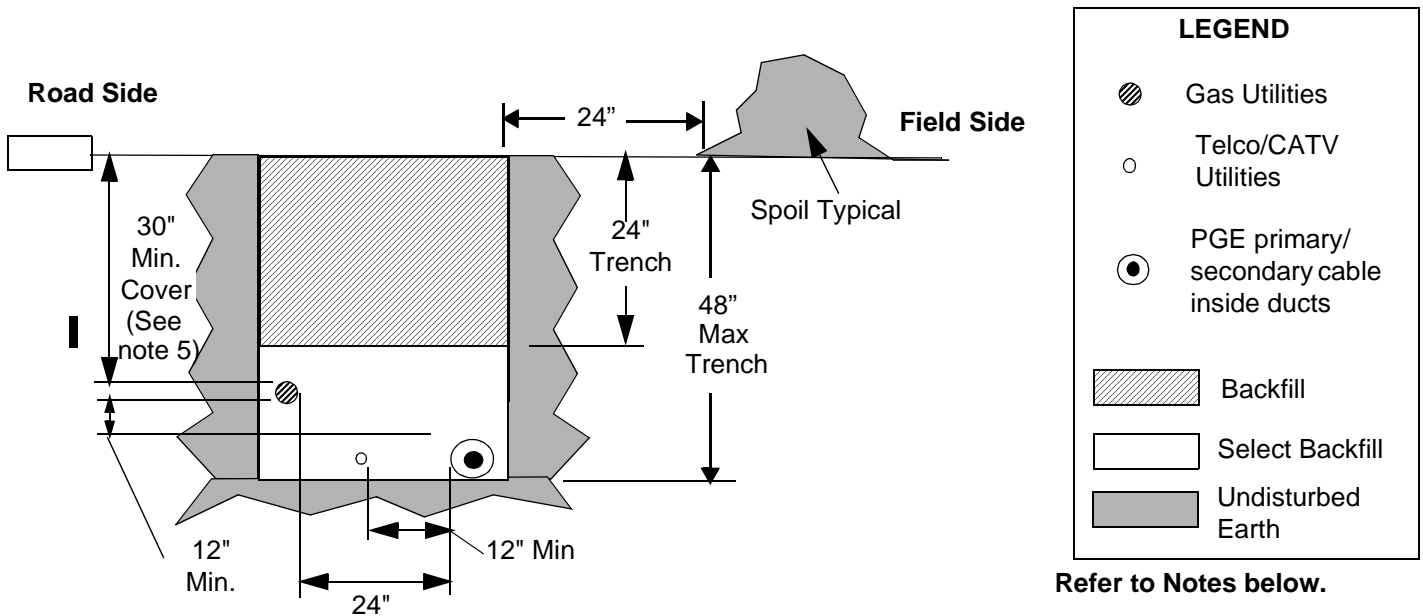

Figure 6-3 Joint Use Mainline Trench

NOTES (Figures 6-1,6- 2 & 6-3):

1. Where on-site backfill contains rocks larger than 4" and/or fractured rock (with sharp corners), select backfill shall be used. Select backfill shall be placed a minimum of 4" below and 6" above the centerline of the conduit/cable configuration, as shown. **Select backfill** material shall pass through a 3/4" sieve and contain no sharp or foreign objects. Backfill in the remainder of the trench shall be free of rocks larger than 4" in diameter.
2. The Customer is responsible for backfilling trenches and site restoration.
3. Depths are min. depth; deeper trenches shall be required by designers for rocky & debris areas since sand cushion will be needed under conductors.
4. Water lines, on private property only, are allowed in trenches with a minimum of one foot vertical and one foot horizontal separation from PGE conductors or conduits.
5. Some local jurisdictions have "minimum cover" requirements greater than 30-inches.

6.2.4 UNITY Service: Install Multiple Services

UNITY service is a joint effort between PGE and Northwest Natural that provides for installation, including trenching and backfilling, of as many as four utilities in one ditch at one time. UNITY is optional for phone and cable TV services. Contact PGE for further information

6.3 Conduit

The Customer shall install either rigid steel or electrical-grade Schedule 40 gray PVC conduit. Sweeps of PVC, rigid steel, and fiberglass are acceptable. All PVC joints shall be glued. If rock or other obstructions are encountered consult PGE. When the conduit terminates at a PGE pole, consult PGE for exact conduit location. [Table 6-1](#) shows minimum conduit requirements.

Table 6-1. Conduit Requirements for Utility Conductors
Secondary Voltage (Under 600 V)

Service Entrance Ampacity	Single-Phase Three Wire	Three-Phase Four Wire*
200A or Less	One 3" (see note e.)	One 3 inch (min.)
320A Continuous	One 3 inch	--
201A to 600A	Two 3"	Two 3" (min.)
800A	Three 3"	Three 3" (min.)
1000A	--	Four 3" (min.)
1200A	--	Five 3" (min.)
1201A and Up	--	Consult PGE

***Consult PGE for conduit sizes for all three-phase services.**

Notes:

- a. 4-inch conduit may be substituted for 3-inch conduit.
- b. Larger conduit size, additional conduits, or larger bend radius may be required for longer runs, four-wire full neutral, or direct connection to utility conduit. Customer shall consult PGE for specific requirements.
- c. See [Figure 6-1](#), [Figure 6-2](#), or [Figure 6-3](#) for normal trench depth.
- d. Customers' service conductors must be in a separate conduit system from PGE conductors.
- e. 3" to 2 1/2" swedge reducer as close as possible to the meter base may be used for 2x4 framing (see Figure 7-4).
- f. Bends to be minimum 36" formed sweep radius. **All bends must be factory made. Field heat bends are not acceptable.** Rigid steel or PGE approved fiberglass bends are required for runs of 151 feet or longer, or for any length run with more than 180 degrees in bends. PVC Schedule 40 bends are acceptable for runs of 150 feet or less. The maximum total bends in any conduit run is 270 degrees.
- g. **Pull line or poly rope capable of withstanding 500 lbs. tension shall be provided by the Customer with 6 feet of line extending from each end of the conduit.** Pull line shall be installed after conduit is joined and glue is dry. When new conduit and/or pull-line will be entering an existing PGE secondary vault or transformer, the installer is required to contact PGE prior to installation. A PGE crew will be scheduled to meet the installer at the site to assist with installation.
- h. PGE will not install conductors if conduit system is improperly constructed. Customers are responsible to proof all conduits they have installed.
- i. All conduit routes must be approved by PGE prior to installation by customer and customer installed conduit must be inspected by PGE before backfill.
- j. During construction customer to mark conduit locations with white paint or other markers (e.g., plastic strips) per OAR 952-001-0070.

- k. The Customer is responsible to recognize potential surface and sub-grade water flows that may allow entry of water into the Customer’s electrical equipment. PGE will coordinate with the Customer to assist in preventing this water entry.

Table 6-2. Fiberglass Sweep Specifications

Diameter (Inches)	Sweep Radius (Inches)	Min. Wall Thickness (Inches)
2 - 4	36	0.070
5-6	60	0.095

Notes:

- a. Each sweep shall require two PVC, extra-deep, fabricated couplings attached.
- b. Sweeps must meet NEMA TC14, *Filament-Wound Reinforced Thermosetting Resin Conduit and Fittings* for IPS design.

6.4 Concrete Pads and Vaults for Padmount Transformers & Metering Equipment

6.4.1 Pads

Customers must consult PGE to obtain drawings and dimensions for concrete pads or vaults for padmount transformers. Pre-cast pads may be acceptable. Pads must be flush with the finished grade within 12” of a sidewalk or other paved area.

6.4.2 Vaults

PGE requires vaults under cable compartments. Consult PGE for transformer vault dimensions. The vault lid is to be installed 2” above the finished grade in landscaped areas and flush with the finished grade within 12” of a sidewalk or other paved area.

6.4.3 Clearances

See [Figure 5-4](#).

6.4.4 Excavation and Backfill

Excavate entire area beneath pad or vault to a depth of 18 inches below final grade. All soil beneath the pad site must be compacted and level prior to setting or pouring the pad or vault to prevent settling. Backfill with compacted 3/4-inch minus gravel to 90 percent compaction of undisturbed earth within 5’ of pad or vault.

6.4.5 Barrier Post

Install 6” diameter steel, concrete-filled barrier post(s) around PGE equipment in areas where the equipment is exposed to vehicle traffic (See Figure 6-4 and Figure 6-5). For additional specifications and other options contact PGE for review and approval.

Figure 6-4 Heavy Duty Barrier Post

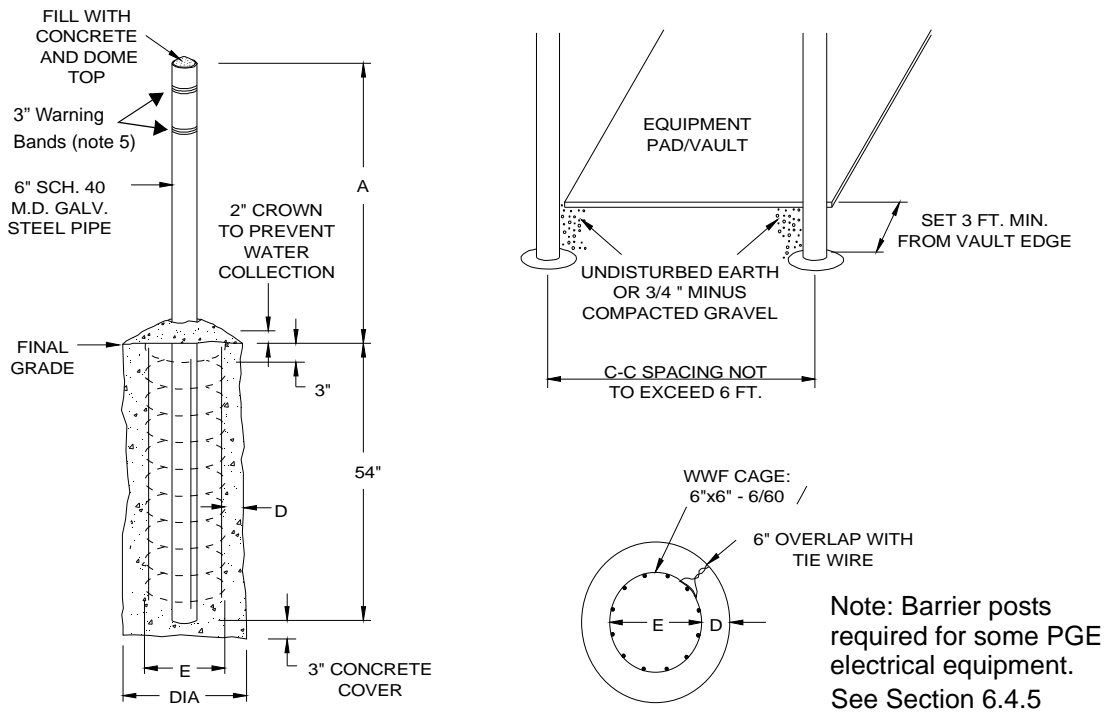

Table 6-3. Barrier Post Details

Type	Dimensions	Hole Dia	Height "A"	Concrete Space "D"	WWF Dia "E"
Loading Docks (Heavy Traffic)	6" Dia x 9'	30"	54"	6"	18"
Parking Lots	6" Dia x 8'	24"	42"	Not Needed	Not Needed

1. Place 6" Schedule 40 M.D. galvanized steel post filled with concrete a maximum of six feet apart on all sides exposed to vehicles.
2. All concrete shall have a minimum compressive strength of 3000 psi after 28 days.
3. Barrier post installation shall be in undisturbed earth. However, the area between the vault wall and barrier hole may be filled with 3/4" minus compacted gravel if three feet of undisturbed area is not available after the vault is set.
4. Steel reinforcement shall be welded wire fabric (WWF), 6" x 6" grid of 6/60 round, formed in a cage as shown above. Reinforcement not required for areas having only car traffic.
5. Posts shall be painted bright yellow. Mark top of post with two 3" warning bands of contrasting colors.

Figure 6-5 Barrier Post Locations at Padmounted Installations.

